

sure

cross[™]
wireless network

sensing unplugged.[™]



BANNER[®]
more sensors, more solutions

**Request
PRINT
Version**

SureCross™ wireless from the most reliable name in sensing.

Process



Factory



Agriculture and Water



Traffic



Commercial



Contents

SureCross Sensing Unplugged™	4
SureCross Advantages	6
System Overview	8
Process Control and Monitoring	10
Factory Automation	12
Agriculture and Water Management	14
Traffic Monitoring and Control	16
Commercial and Consumer Monitoring	18
SureCross Options	20
SureCross Configuration	21
SureCross Configured Kits	22
SureCross Gateway and Node Models	23
SureCross Accessories	24
SureCross Antenna Options	26
SureCross Specifications and Dimensions	27





Key Wireless Terms

FHSS - Frequency Hopping Spread Spectrum. A method for generating spread spectrum transmissions where the signal is switched between different frequency channels in a pseudorandom sequence known by both the transmitter and the receiver pair. FHSS is useful for sending small, redundant packets of data in a high interference environment.

FlexPower™ systems allow for a true wireless solution as the Node can be powered by line power (10-30V dc), solar panels, or battery power (3.6-5.5V dc). A SureCross™ FlexPower battery module and unique power management system runs the Node and a device for up to five years, depending upon the power requirements of the device. Battery life is application specific.

RF - Radio Frequency. Electro-magnetic signals in the radio band.

Rx/Tx - Receive. Transmit.

TDMA - Time Division Multiple Access. A wireless network communication architecture that provides a given slot of time for each device on the network. Provides guaranteed opportunity for each device to transmit to the gateway.



When the world thinks of sensors, it thinks of Banner.

With more than 17,000 photoelectric, ultrasonic and vision sensors, and safety products available worldwide, Banner is the most innovative, most experienced name in sensors. For simple to complex applications, Banner has more sensor solutions than any other manufacturer.

The innovation leader with more than 40 years of sensor development and application expertise, Banner understands the challenges of sensing in manufacturing and process industries. Banner has more than 3,000 factory and field representatives worldwide, as well as the largest force of application engineers in the industry who solve thousands of the most challenging applications every year.



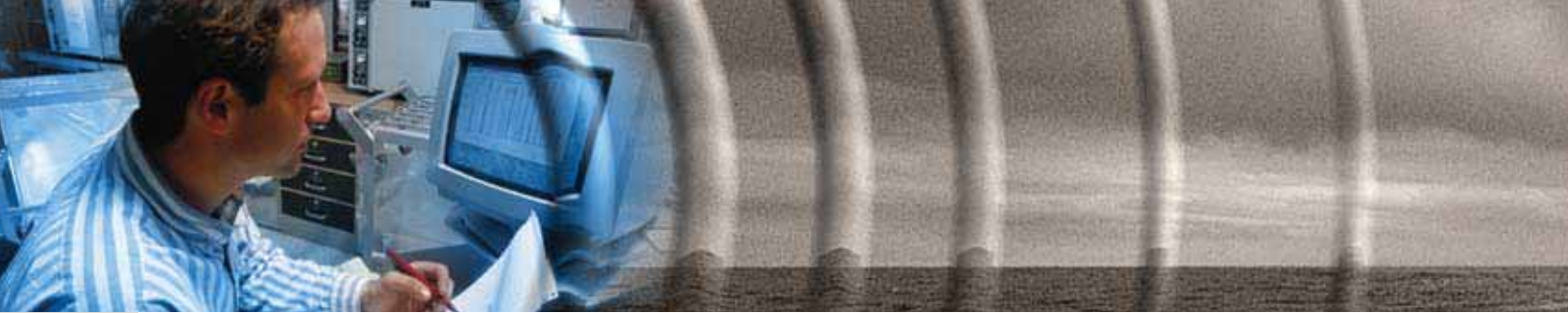

Introducing SureCross™. Sensing unplugged.™

A New Wireless Horizon from the Most Reliable Name in Sensors.

To satisfy the performance demands for reliable sensing and actuation, Banner has reinvented wireless. The SureCross™ Wireless Network is the first wireless platform built from the ground up for industry—featuring proprietary RF design, power management with battery and solar options, and a host of low-power sensors designed to deliver robust remote monitoring and control capabilities.

With SureCross, Banner's comprehensive sensor capabilities are extended through wireless connectivity, often to locations and applications never before possible. Plant and process visibility becomes panoramic. Orphaned monitoring resources are integrated into existing control systems. Assets are unlocked. Vast new monitoring and actuating capabilities can be easily created. SureCross provides the means to fulfill the promise of comprehensive, facility-wide integrated management.

Add Monitoring. Add Control. Where You Need it Most.

The flexibility of the SureCross network lets you add a host of monitoring and control capabilities across widespread areas and to inaccessible areas, and enhances existing control and data acquisition systems without new conduit, wiring runs and associated labor and downtime. Consolidate comprehensive system status at a single location using multiple SureCross networks, delivering single or multiple field measurements interfaced to your control room PC, PLC or DCS system. The SureCross wireless network is as powerful as your imagination.

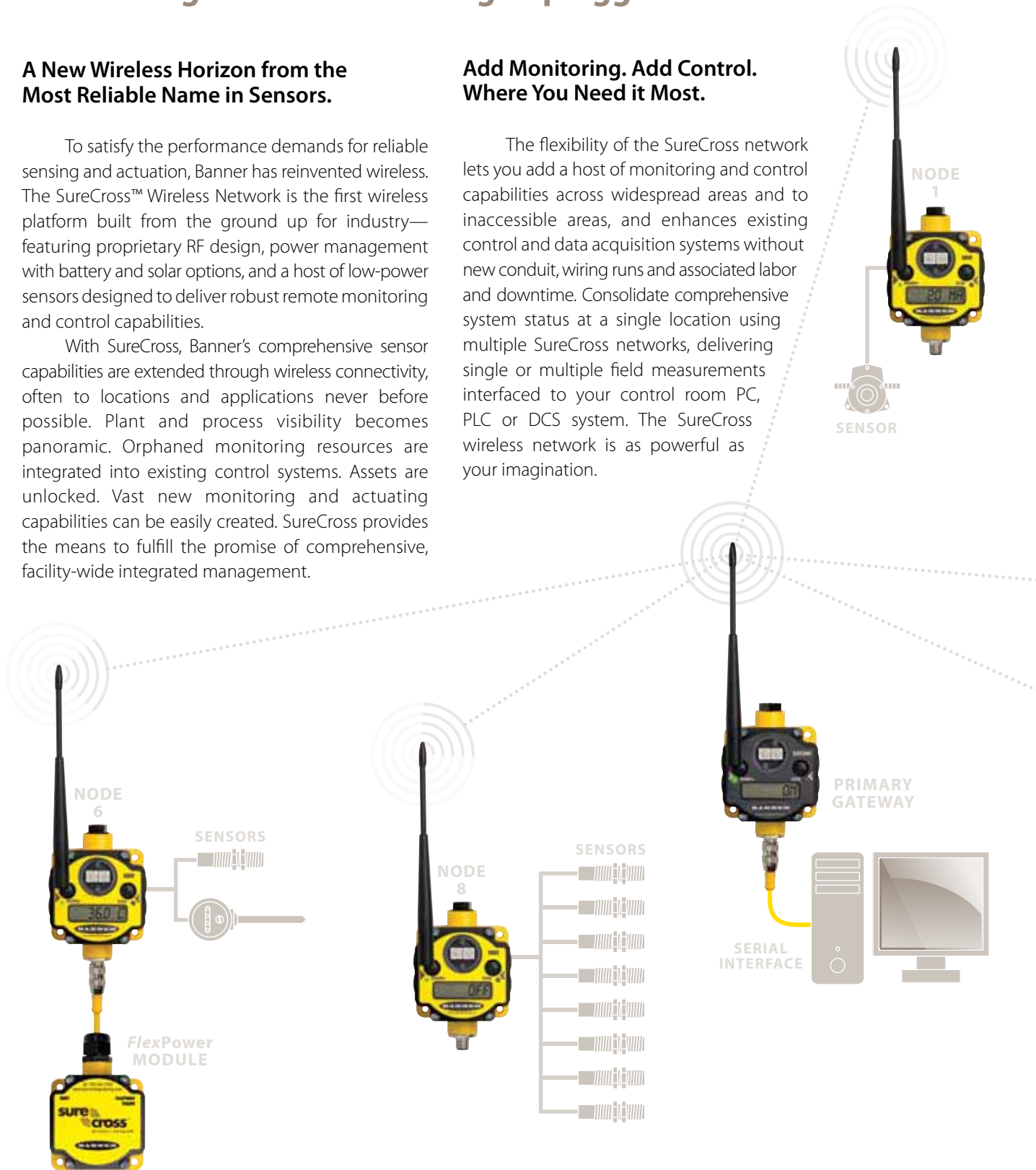



900MHz 2.4GHz

Easy to Apply Wireless Modules Go Where Other Systems Can't.

The Banner SureCross Wireless System is a radio device network with integrated I/O that can operate in extreme environments while eliminating the need for costly wiring runs. The most basic SureCross network includes a Gateway system controller and one or more Nodes that monitor and/or control I/O in remote locations. Nodes are easily deployed throughout a facility, for gathering data to be concentrated at the Gateway. Installation is fast and easy with flexible mounting and power options. Nodes can be either line-powered (10 to 30V dc) or *FlexPowered* with multi-year battery life providing power for communications and to external sensors.

The Gateway can act as a master device in a star topology autonomously controlling input to output mapping, or a Modbus Slave in a host control system using RS-485 Modbus RTU. To relay mapped I/O longer distances, a Gateway can be positioned between two Nodes to increase transmission range of the network.

SureCross is distinctly superior to conventional wireless networks, facilitating sensing and actuation on the same network. Not to mention its ability to transmit the status of each I/O point and continuously monitor the health of each Node's operational status and signal integrity.

SureCross offers easy, reliable communication between disparate products and processes in a single scalable and unified platform.

- Access hard-to-reach locations; install where wiring and conduit are not practical
- Accommodates digital and analog I/O in a single unit
- Integrates with existing process or control networks
- Easy to retrofit, expand and relocate as needed
- 900 MHz and 2.4 GHz models accommodate worldwide communication standards
- Reliable and secure Frequency Hopping Spread Spectrum (FHSS) protocol
- Bidirectional Rx/Tx communications between Gateway and Nodes
- Mobile, scalable and flexible
- Easy plug-and-play deployment
- Rugged IP67/NEMA 6 design
- *FlexPower™* supply options including battery and solar

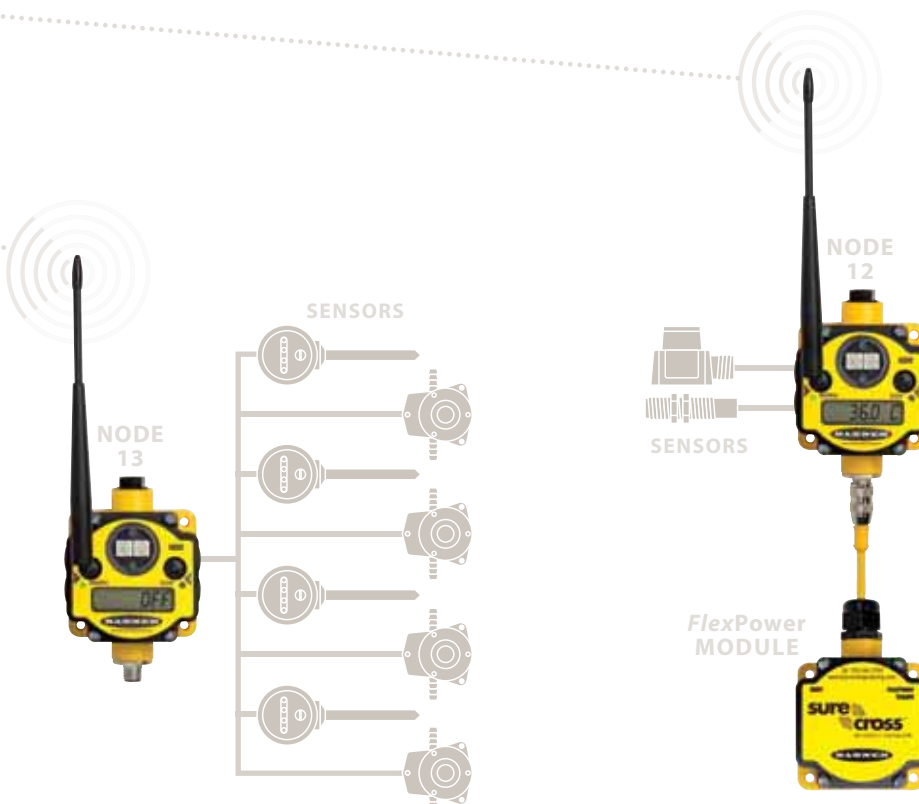



SureCross™. Purpose-built by Banner.

While wireless monitoring is far from new, Industry has had to wait patiently for robust bidirectional network devices that offer a feature set designed specifically to meet the demands of manufacturing, processing and challenging commercial applications.

The wait is over.

Banner designed and built the SureCross network using over 40 years of application expertise and sensor innovation. Unlike other wireless devices, Banner started with the high-performance needs of Industry and developed a system that meets those needs. The result is a superior network with exclusive features, engineered and built by the sensor experts trusted worldwide.



Proprietary Radio Communications

In industrial applications, there can be no compromise for truly robust, secure communication that ensures system operational integrity. That's why Banner built its own RF model based on essential sensing requirements with bidirectional Rx/Tx communication capabilities.

Advanced Power Management

True wireless operation means integrated power not only for communications, but also for operating the attached sensor. Banner developed an innovative *FlexPower™* solution that offers years of continuous operation. Innovation in wireless power management combines ideally with Banner's ability to design advanced sensors that consume less power. SureCross also accommodates DC line, battery or solar power for complete application flexibility.

Reliable Response

SureCross represents a quantum leap in wireless capabilities with deterministic response—a system that lets you define actions and system responses to communication interruptions or failures. Each SureCross device features a bidirectional transceiver to fully acknowledge data transmission. The Gateway directs Nodes in the network to respond with specific actions to a communication failure by driving user-defined outputs to a default condition. Once the RF link is re-established, the network automatically returns to normal operation.

Communications Integrity Assured

SureCross uses a Frequency Hopping Spread Spectrum (FHSS) transmission method to minimize radio interference, ensuring that the message gets through and providing integral security. Time Division Multiple Access (TDMA) slots provide guaranteed bandwidth to each connected Node. Polling and Site Survey capabilities ensure communication integrity. SureCross offers both 900 MHz and 2.4 GHz models, allowing you to deploy advanced wireless capabilities anywhere in the world.

All-in-One Packaged Solution with Plug-and-Play Connectivity

Gateways and Nodes are rugged, completely integrated and packaged solutions designed for mounting flexibility, extreme durability and plug-and-play installation. Wiring terminals are readily accessible without removal from mounting. The compact housings come equipped with quick-disconnect connectors for power and communication, four cable glands and a large threaded 1/2-inch NPT port for added flexibility.

Versatile Configurations

Configure your SureCross wireless network with Gateway and Node components set to your specifications. Or choose SureCross Kits that are configured for a number of common applications. Either way, Banner can help you select the exact components, tailor your solution, or help you choose a kit that delivers the performance you need. Banner Application Engineers are available to provide SureCross configurations that integrate seamlessly into your legacy systems and solve your most demanding applications.



SureCross™ . Powerful Capabilities. Sophisticated Functionality.

Robust. Reliable. Secure.

The SureCross network uses a Frequency Hopping Spread Spectrum (FHSS) methodology in either the 900 MHz frequency band or 2.4 GHz frequency band. FHSS architecture periodically "hops" in a random sequence from frequency to frequency. This technique not only prevents interference from competing RF signals, it also enhances security. Multiple user-selectable hop codes are easily configured by setting the Network ID using a convenient rotary switch. FHSS innovation also enables multiple SureCross networks to coexist within range of one another.

To further ensure reliable communications, SureCross uses Cyclical Redundancy Checking (CRC) of both data message acknowledgement and data error checking to verify message receipt and data integrity. If the Gateway does not accurately receive a data packet, the Node resends that packet until a transmission is successful. Finally, communication is enhanced through TDMA, ensuring each Node a time slot for transmission.



Tests Signal Integrity Locally.

Every SureCross network includes an embedded Site Survey feature. The Site Survey which is conducted between the Gateway and each Node, is a fast, simple and reliable way to ensure that every device is installed for optimal RF performance. Signal results are displayed in a red, green, yellow and missed format. Identified using a flashing LED of the corresponding color and an alpha character on the LCD screen, green, yellow and red indicate successful data transmission. No flashing LED and an M on the LCD indicates a missed packet has occurred and the data was not received successfully on the first transmission. The message is resent until it is received successfully.

Green = Excellent

Yellow = Good

Red = Marginal

Missed = Data not received on the first transmission

Engineered Simplicity.

- A) External Antenna Interface—external flexible antennas rotate for mounting and positioning versatility; optional internal and remote, standard and high-gain antennas available
- B) Network Identity and Device Address Rotary Switches—easy-to-set and change; with screw-on cover
- C) Menu and Configuration Access Push Buttons—click through menu-driven configuration
- D) LED Status Indicators—give real-time feedback of RF link status, serial communication activity and error state
- E) LCD Display—six-character display provides run mode user information and shows enabled I/O point status; lets user conduct Site Survey, assign network ID and modify other configuration parameters locally without a PC or external software interfaces
- F) Internal Wiring Terminal—16 spring-clip type terminals (AWG 12-28); are accessible without removal from mount
- G) 1/2-inch NPT Threaded Port—accepts large cables for flexible wiring options or glands; plug provided
- H) IEC IP67; NEMA 6 Rated Housing—ensures reliable, long-lasting performance in rugged environments
- I) Four PG-7 Gland Ports—threaded ports accept provided cable glands or blanks
- J) Versatile Mounting—#10/M5 hardware included with optional DIN-rail mount adapter
- K) 5-Pin M12 Euro-style Quick-Disconnect Fitting—simplifies installation with industry-standard connectors



FlexPower™ SYSTEMS

Predictable. Reliable. Repeatable.

SureCross FlexPower options create a truly wireless sensing system. Users can choose from battery, solar or line power options. Efficient power management technology enables the FlexPower battery system to briefly step up the switch power voltage to activate a sensor device. Once activated, the input reads the sensor then the switch power shuts off to prolong battery life—up to 5 years. The actuation voltage, time on and sample are configurable parameters, with voltage up to 24V dc. These unprecedented capabilities provide a reliable solution for remote power and hard-to-access locations.

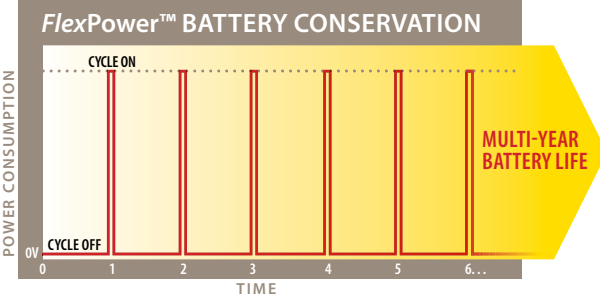



Enhancing monitoring or control in legacy process environments is now simple and affordable. Banner SureCross™ Nodes and Gateways can be easily deployed wherever additional monitoring is desired, without hardwiring and conduit. Control capabilities featuring Banner sensors and a wide range of industrial communication protocols can also be added.



The Versatile, Robust Wireless Network Designed for Process Applications.

Monitoring and control in processing applications are limited only by imagination. From tank levels to line pressure, from temperature to voltage—anywhere along the line, the versatile SureCross™ Wireless Network can be deployed, scaled and redeployed. Adding new Nodes or establishing multiple networks within the same environment is turnkey. Bidirectional transmission with reliable performance capabilities make SureCross the first robust wireless network suited for a host of process applications.

The SureCross Wireless Network features a configurable default output condition that defines what happens if the system loses the RF signal. This unique network characteristic lets you define how all outputs on the network respond to a communication interruption or failure. The network can automatically return to normal operational status as the RF link is re-established.

A SureCross Gateway can be positioned as a repeater to increase the transmission range. Data can be consolidated and monitored from a central location, enhancing production decision-making and response.

Wireless Monitoring Retrofit in a Pre-Certified Facility

New regulations in a pharmaceutical production facility stipulate the liquid level of all fluids must be closely monitored and logged. SureCross Nodes with *FlexPower™* and Banner U-GAGE® QT50U analog sensors quickly and easily facilitate this monitoring requirement without new construction and hardwiring.

Motor Temperature Monitoring and Control

Monitoring motor temperature in a high-friction application is controlled by a line-powered SureCross Node and a Banner T-GAGE® temperature sensor. The SureCross Gateway transmits operational conditions to the plant control room using a digital output related to temperature setpoints within the sensor. The motor is powered down or up based on these temperatures.

Monitoring of Rotating Equipment

The SureCross wireless network eliminates complexities associated with data acquisition from rotating and moving machinery such as a rotating kiln. Crucial temperature data is acquired using a thermocouple and transmitted from the *FlexPowered* SureCross Nodes to a remote Gateway in the plant's control center. Excessive heat triggers an alarm. Data is always concentrated in the same location for processing or analysis, and physical risks to personnel are eliminated.

Remote and Tank Farm Monitoring

Monitoring levels, pressure, flow rates or temperatures from difficult-to-access platforms, towers and large tank farms has historically been a significant challenge. Today, *FlexPowered* SureCross Wireless Nodes equipped with low-powered sensors can monitor and acquire data remotely, overcoming logistical hurdles and eliminating risk to personnel.



EXAMPLE APPLICATIONS

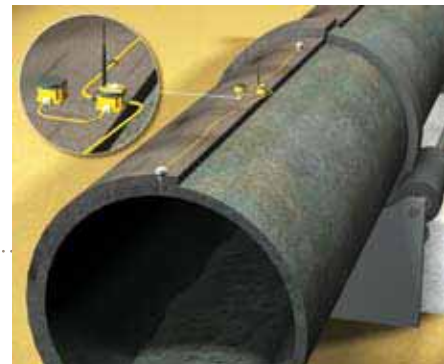



EXAMPLE APPLICATIONS



The Gateway to Error-Proofing Manufacturing.

The Banner Wireless Network is the cost-effective key to making existing manufacturing facilities and process tasks align with efficient lean production principles. Hosts of Wireless Nodes can be deployed across the production floor to add new remote monitoring and control capabilities to existing machinery, as well as to implement systems that optimize inventory, reduce errors and minimize waste.



At the heart of lean production is the ability to make small changes and refinements. Lean is not a single solution, but a combination of small steps that contribute to continuous improvement. The versatile Banner Wireless Network offers the ability to quickly implement, move, change, expand and refine processes as your needs change.

Where new wiring for power or communications is impractical, a Banner Wireless Network can be implemented with battery-driven *FlexPower™* Nodes that provide both power for connected or integrated sensors, as well as communication to a remote Gateway. Now entire error-proofing and monitoring systems become portable for redeployment at will, and installing sensors in locations and on equipment is now possible where never before.

Banner Wireless Nodes and Gateways reliably orchestrate Banner EZ-LIGHT™ pick-to-light sensing systems to virtually eliminate human error from parts picking and assembly processes. Wireless parts-call automation keeps line inventories replenished and saves floor space. Manufacturing, assembly, kitting and verification processes run more efficiently with greatly reduced errors.

Rotating Equipment Monitoring

Battery-powered Banner Wireless Nodes remotely transmit data without hardwired power cables to monitor and control rotating machines while eliminating costly and cumbersome slip rings.

Automated Parts Call

Remote, self-contained push buttons attached to Banner Wireless Nodes can be placed at assembly line workstations to signal a Wireless Gateway-equipped automated guided vehicle (AGV) for replenishment of assembly parts.

Error-Proofing Manufacturing

Applying lean manufacturing principles in existing assembly facilities is easily and economically facilitated by Banner EZ-LIGHT operator indicator lights and pick-to-light systems applied across a Banner Wireless Network.

Robot End Effector

To eliminate frequent and unpredictable slip rings or flex cable failure on robotic arms, a SureCross Wireless Node with *FlexPower* Module monitors the end effector. Two NAMUR proximity sensors, each powered by the *FlexPower* Module, are characterized for power draw, allowing predictable, scheduled replacement of the battery.



Wireless Conveyor Monitoring. Banner Wireless Nodes with optional *FlexPower™* and low-power Banner sensors combine to create a portable monitoring system that instantly integrates into a legacy overhead conveyor without new hardwiring. Nodes travel with the product, providing remote monitoring and control using the Wireless Gateway.



Agriculture and Water Management

Monitoring operational status in critical systems such as barn ventilation or temperature control equipment can prevent loss of livestock or spoilage of other resources that can occur within minutes of a power loss. A SureCross™ Wireless Node equipped with FlexPower™ and a flow sensor is isolated from the power grid to monitor system status, issue alarms and notifications, and/or to trigger backup power systems to restore environmental conditions.



Remote and Field-Based Monitoring is Now a Reality.

Field-based agribusiness and water management applications have long suffered from the inability to monitor operational status, levels, temperature and other crucial information. Now the convergence of the powerful SureCross™ Wireless Network and the longevity of SureCross FlexPower™ supplies provide easy-to-apply solutions to the toughest monitoring challenges.

A host of SureCross antennas, power options, connectivity solutions and a complete range of sensors offer capabilities never before available. Solutions can be easily integrated within, or provide output to, existing operations and management software.

Banner has taken the robust RF performance and bidirectional Rx/Tx communication capabilities of SureCross to deliver the first practical, wireless network for monitoring and control. FHSS communication protocol plus fully-acknowledged data transfer provide unprecedented communications reliability, but only Banner's configurable default output condition can provide the predictable response needed for critical control applications. With configurable default output conditions, your system's response to wireless signal interruption is in your control, allowing an actuator, valve or similar device to engage, disengage or hold—returning the system to a known status and/or triggering other system events until transmission integrity is re-established.

Rugged IP67 SureCross Nodes are built to perform in the most severe environments and outdoor locations, including agricultural and agribusiness applications. Temperature extremes, dust, moisture and remote locations demand rugged, self-contained monitoring solutions. And SureCross solutions are built to handle it. Continuous, reliable monitoring of resources, status, temperature, flow, levels and more help to optimize ag-based operations and maximize yields while reducing losses and waste.

EXAMPLE APPLICATIONS





Environmental Temperature and Humidity Monitoring

SureCross™ Wireless Nodes equipped with *FlexPower™* and a thermocouple or RTD can be easily implemented for monitoring optimal barn temperature ranges or dairy bulk tank temperatures, triggering a setpoint alarm if the acceptable range is exceeded. Specialized Nodes can accommodate temperature and humidity sensors for monitoring and alarm output on one device.

Air Flow/Ventilation Monitoring

The ventilation system is monitored with a flow meter attached to a Flex Node. An alarm is sent if the system fails, enabling the staff to take action in the case of a lightning strike or other unpredictable events that can lead to the loss of livestock.

Ethanol Plant Water Monitoring

Ethanol processing facilities can use millions of gallons of water per day. SureCross Wireless Nodes equipped with *FlexPower* and pressure sensors can precisely monitor critical water holding tank levels, sending data to a SureCross Gateway and Banner EZ-LIGHT™ status indicator in a remote control center location.

Municipal Water Monitoring

Monitoring multiple data points including fill level, pH, conductivity and flow—often from varied locations in a large water treatment plant—can be a challenge. With four analog inputs, a single SureCross Node can easily centralize and transmit critical monitoring information.

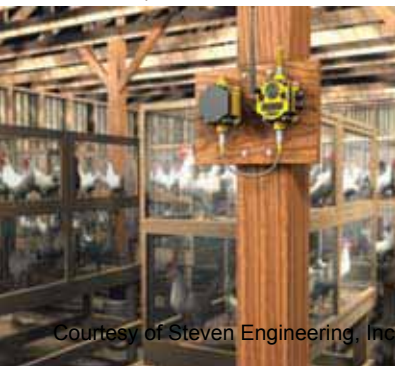

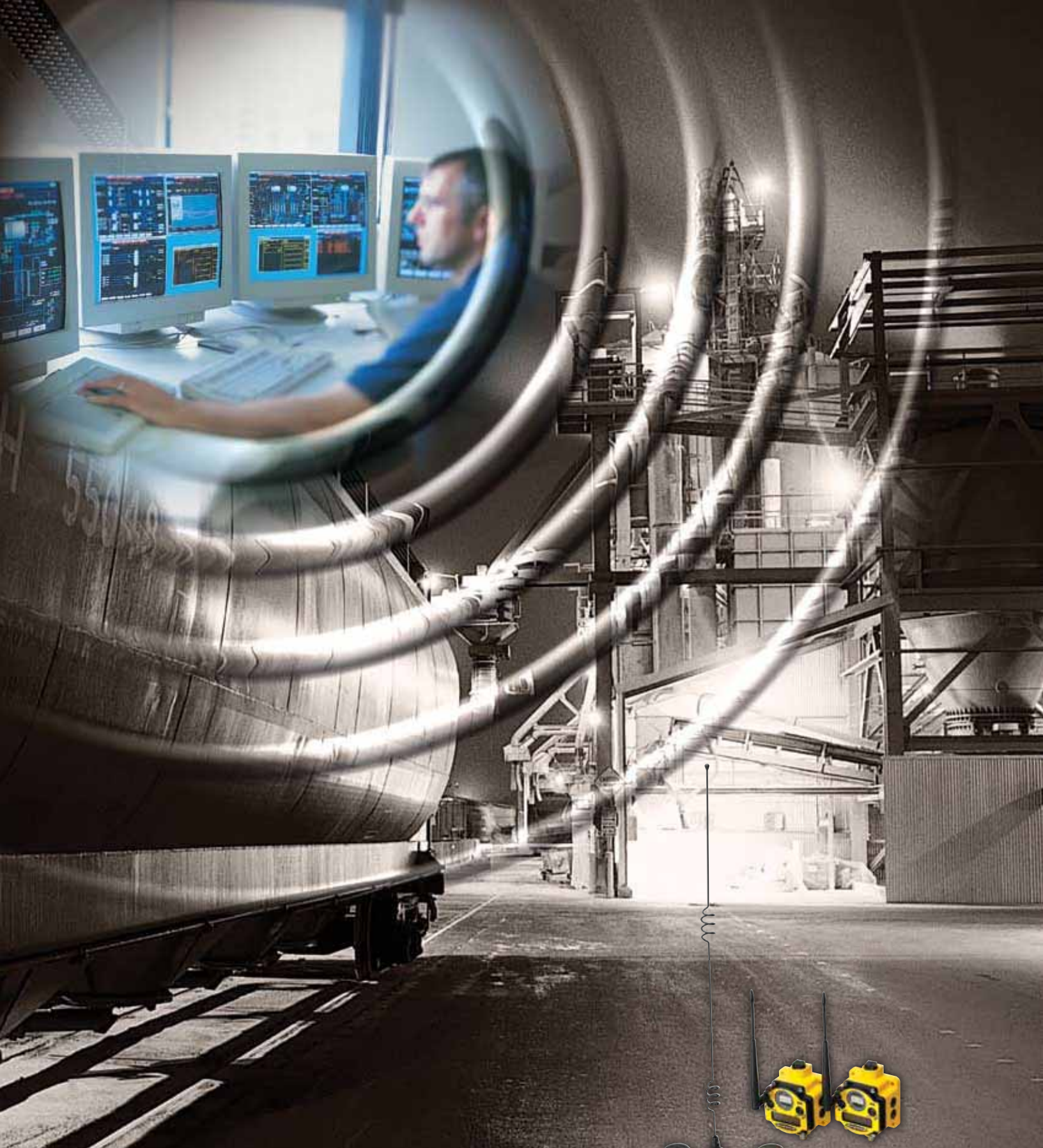

Rail Transport Car Positioning

M-GAGE™ Wireless Sensor Nodes embedded into tracks signal the arrival and facilitate positioning of hoppers, tank and freight cars for loading and unloading. EZ-LIGHT™ signals indicate rail car position to optimally align cars to spouts, elevators and nozzles for more efficient transfers.



A More Dependable and Rugged Sensing Solution for the Demands of Traffic Management.



Conventional embedded solutions for traffic management and control, such as fragile inductive loop detection (ILD) systems, are significantly prone to failure. High failure rates associated with ILD systems not only create inaccurate data that can lead to inefficient traffic management, but make frequent and difficult replacement of in-pavement inductive loops and weakened pavement integrity a harsh reality.

Banner SureCross™ Wireless Networking greatly improves the performance and reliability of embedded traffic management and control sensors. By doing away with the fragile inductive loop, installation, service and operational life are exponentially increased.

Instead, ILDs are replaced by a wireless Banner M-GAGE™ sensor and integrated FlexPower™ battery supply, encapsulated in a rugged IP67 SureCross Node housing. The M-GAGE vehicle detection sensor is a passive, non-contact magnetic receiver that reliably detects 3-dimensional changes in the Earth's natural magnetic field caused by the presence of large ferrous objects.

The SureCross Wireless M-GAGE sensor replaces inductive loop systems and can be used in applications such as car wash entry/exit, opening and closing high-traffic doors and detecting vehicles at drive-thru systems and turn lanes. This dedicated solution—developed specifically for wireless presence sensing—simplifies in-ground installation and offers quick and easy access for battery replacement after up to ten years of trouble-free operation.

Automated Car Wash Detection

Vehicle presence is detected by an in-ground embedded M-GAGE Wireless Sensor Node that activates the automated car wash system to power up and trigger the entry door. The payment system and the car wash remain in a low-power consumption standby mode until a customer arrives. It also eliminates the inevitability of complex and costly inductive loop repair.

Loading Dock Occupancy Monitoring

For optimum workflow and loading dock traffic management, it's essential for dock workers to know of arrivals immediately. M-GAGE Wireless Sensor Nodes mounted on each loading bay signal the arrival of vehicles by illuminating remotely mounted Banner EZ-LIGHT™ indicators that are visible throughout the facility. Supervisors can also be alerted to arrivals using their PC or PDA. Workers assemble quicker at the appropriate dock, cargo security and facility access are greatly enhanced and docks are freed-up faster. Best of all, no through-wall wiring installation is required to implement the system.

Parking Kiosk Access and Control

An embedded M-GAGE Wireless Sensor Node detects approaching vehicles to activate automated parking control systems, payment kiosks and automated access control barriers.

Train Yard Marshalling

Rugged IP67 M-GAGE Wireless Sensor Nodes embedded at various points in tracks can be used for accurate remote monitoring of train car location and marshalling. As cars pass from one sensor to another at changeover locations, track controls can be activated to handle switching of subsequent cars.

EXAMPLE APPLICATIONS

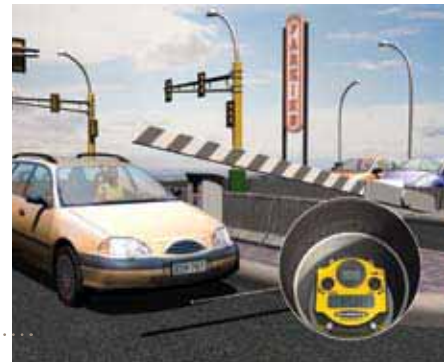



To monitor and control access of secure or supply areas, Banner SureCross™ provides turnkey wireless solutions. Highly reliable security and response systems are easily retrofitted into existing facilities to monitor access and control entry, providing alarms or notifications if doors are opened or left unclosed, or if emergency exits have been opened.



Modular Monitoring Capabilities.

Whether facility-wide or with a single-node, the SureCross™ Wireless Network facilitates adding capabilities for monitoring, security and essential control with ease, low cost and little-to-no disruption of existing systems. Easy-to-apply SureCross Wireless Kits offer a complete, modular system that you can apply and move as needed to different locations and for diverse applications. *FlexPower™* battery options create a completely portable system that is sensing unplugged. Systems can be expanded as needed, and networks can be combined or divided as needs change.

Continuous, reliable facilities monitoring—whether for security, operational efficiency or condition—ensures smooth operation 24/7/365. Rudimentary security and access challenges can be quickly addressed with any number of photoelectric proximity sensors, contact closures, switches and detection sensors that, when connected to a Node, can communicate wirelessly to the Gateway in facility control centers or security offices. Alarms and signal output to switches can trigger desired responses within larger integrated systems. With the SureCross Wireless Network, monitoring capabilities and responses can be embedded wherever needed.





EXAMPLE APPLICATIONS

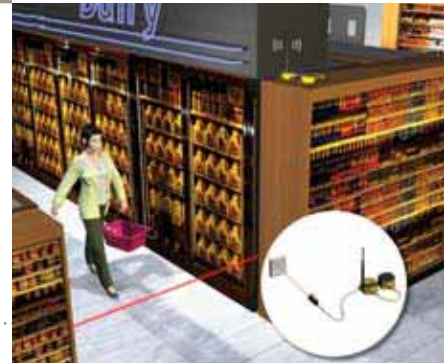

Energy Monitoring/Management

A rooftop HVAC system can be activated based on facility requirements through a Wireless Gateway located inside a facility's physical plant. With this monitoring system, industry managers identify opportunities where their facility could be more energy efficient and conserve plant resources.

Security/Access Monitoring

To monitor and control the entry to storage rooms in the back of a large facility, a proximity sensor is used with a *FlexPower* Node. When the door is opened or closed an EZ-LIGHT™ connected to the Gateway signals the main office.

Retail Traffic Analysis

To understand traffic flow and consumer habits in a retail environment, a SureCross *FlexPower* Node and a Banner MINI-BEAM® sensor provide a discrete, peel-and-stick monitoring and counting solution. Moved about the location to assess retail traffic and optimal store layout, this versatile system provides data to the Gateway located in the management offices.

Refrigeration System Temperature Monitoring

A SureCross *FlexPower* Node used with an RTD ensures an optimal temperature is maintained within large cold chain storage systems for refrigeration, walk-in coolers, freezers or standard grocery cases. The remote Gateway is located off the floor and issues an alarm to management personnel if the temperature exceeds acceptable limits.

SureCross™ Gateway and Node Possibilities

- I/O can be tailored to accommodate up to 12 functions per device.
- Open design supports inputs from sensors and devices from Banner and other manufacturers.
- Multiple network and protocol options make it easy to link to industrial host systems.
- *FlexPower™* devices enable sensing solutions never before possible.

What type of sensors need to be wireless?

SureCross works with:

- Photoelectric
- Ultrasonic
- Inductive
- Capacitive
- Contact Closures
- Thermocouple
- Pressure
- Thermistor
- Distance
- RTD
- Level
- Flow



Do you use Serial Comms?

SureCross supports:

- Modbus RTU RS-485
- Modbus RTU RS-232
- Modbus TCP/IP
- EtherNet/IP



How much I/O?

SureCross can provide:

- Up to 4 Analog IN (current, voltage)
- Up to 8 Discrete IN (sinking, sourcing)
- Up to 4 Analog OUT (current, voltage)
- Up to 8 Discrete OUT (sinking, sourcing)



What types of power are available?

SureCross power options:

- 10 to 30V dc
- AC options
- *FlexPower* supply options:
 - FlexPower Battery Modules*
 - FlexPower Solar Modules*



SureCross™ Configuration: Engineered Your Way

- Configured Kits are only a starting point; add Nodes through the configurable Gateway to expand an application solution.
- Custom setup of I/O function, timing and network health monitoring is handled through a configurable Gateway.

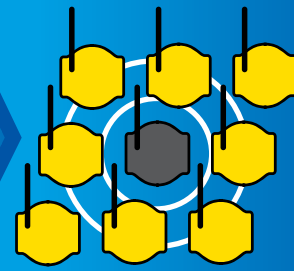
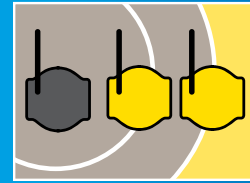

SureCross™ Configured Kits.

Banner offers a large number of SureCross wireless kits that are configured with everything you need to solve many common applications quickly and easily. Preset functionality makes the network easy to deploy and operate.

SureCross™ Unlimited Solutions.

Whatever the demands of your application, configurable Gateways and Nodes can be set to solve your most challenging remote sensing scenarios. Configuration allows the assembly of wireless networks using the exact SureCross components required.

Modify

- Alter Presets
- Expand Configuration
- FlexPower™ Settings
- Custom Solution

ENGINEERED APPLICATIONS

SureCross™ Configured Kit

This application employs two NAMUR proximity sensors that interface with the FlexPower Node. Based on the power consumptive properties of the sensors and the required sample interval of 250 milliseconds it was calculated that the DX81 FlexPower supply would last one year. Banner is continuously building a library of characterized sensors from different manufacturers to make FlexPower solutions plug-and-play.

Cable Method

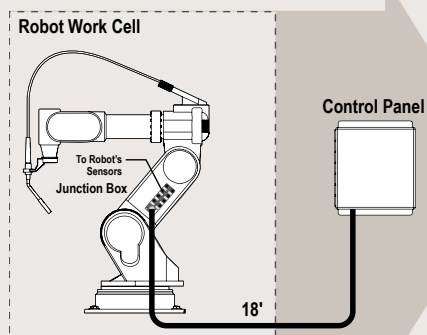

SureCross™ Method

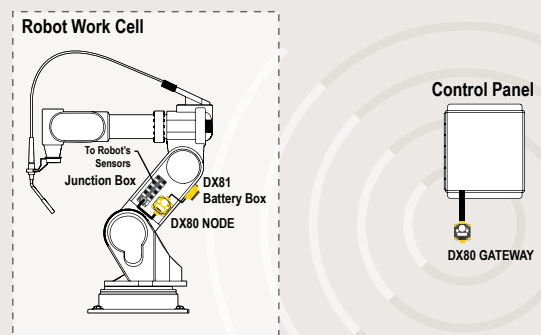

More information online at bannerengineering.com



SureCross™ Plug-and-Play: Configured Kits

- One box houses the preset Gateway, Node(s), accessories and hardware to get you up and running quickly.
- The Gateway is configured to independently control I/O mapping for all devices within the kit.
- Network traits are preset to provide discrete I/O on change of state and periodic reporting of analog I/O.

Discrete†

Model Number	Frequency	Icon*	Gateway I/O	Node 1 I/O	Node 2 I/O	Node 3 I/O	Node 4 I/O	Data Sheet
DX80K9M6DP1	900 MHz		Discrete 4 IN & 4 OUT	Discrete 4 IN & 4 OUT				129306
DX80K2M6DP1	2.4 GHz							
DX80K9M6DP4	900 MHz							
DX80K2M6DP4	2.4 GHz							Discrete 1 IN & 1 OUT



Analog & Discrete†

Model Number	Frequency	Icon*	Gateway I/O	Node 1 I/O	Node 2 I/O	Data Sheet
DX80K9M6MP1	900 MHz		Discrete 2 IN & 2 OUT Analog 2 IN & 2 OUT	Discrete 2 IN & 2 OUT Analog 2 IN & 2 OUT		129312
DX80K2M6MP1	2.4 GHz					
DX80K9M6MP2	900 MHz					
DX80K9M6MP2	2.4 GHz					Discrete 1 IN & 1 OUT Analog 1 IN & 1 OUT



FlexPower™ Systems

Model Number	Frequency	Icon*	Gateway I/O	Node 1 I/O	Notes	Data Sheet
DX80K9M3PE1	900 MHz		Discrete 2 OUT (sinking)	Discrete 1 IN (FlexPower™ supply configured for MINI-BEAM) 1 IN (passive)	DX81 FlexPower supply included; provides power for FlexPower Node and MINI-BEAM	129318
DX80K2M3PE1	2.4 GHz					
DX80K9M3GE1	900 MHz					
DX80K2M3GE1	2.4 GHz					Discrete 2 OUT (sinking) Analog 2 OUT (0-20 mA)



* = Gateway = Node † = Discrete outputs are sourcing unless otherwise noted. Analog outputs are 0-20 mA.

ENGINEERED APPLICATIONS

SureCross™ Unlimited Solutions

This application employs a configurable Gateway, a FlexPower Node and a 10 to 30V dc Node. The Gateway provides two functions: first to determine the appropriate valve control actuation and second, to extend transmission range for the application up to 6 miles. The FlexPower Node is located in a remote location without access to power and cycles periodically to collect flow data for media. Based on this data, the Gateway dictates the open and close action of the valve to the output on the 10 to 30V dc Node, which is located on the valve.

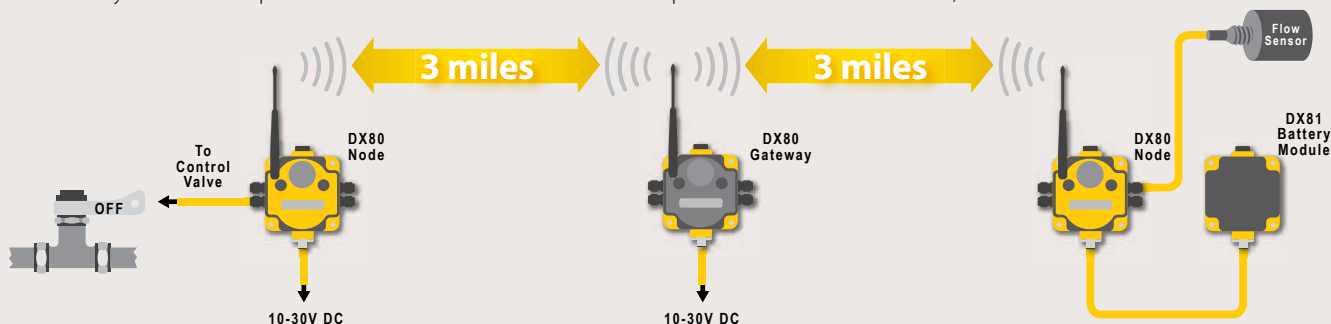

More information online at bannerengineering.com

SureCross™ Gateway and Node Models

- A network consists of one Gateway and one or more Nodes that operate in the same frequency band.
- Each Network accommodates one Gateway and any combination of Nodes shown in the table below.
- Input-to-output mapping is controlled by a configured Gateway or supported through serial communication.
- Multiple antenna options available; internal antenna recommended for ranges less than 500 ft, external antennas enable ranges up to 3 miles.

Gateways 10 to 30V dc

Model Number	Frequency	I/O		Antenna	Data Sheet
DX80G9M6W4P4	900 MHz	Modbus Enabled	Discrete 4 IN & 4 OUT (sourcing)(sourcing)	Internal	131291
DX80G9M6S4P4				External	
DX80G2M6W4P4	Internal				
DX80G2M6S4P4	External				
DX80G9M6W2P2M2M2	900 MHz	Modbus Enabled	Discrete 2 IN & 2 OUT (sourcing)(sourcing)	Analog 2 IN & 2 OUT (0-20 mA)(0-20 mA)	131292
DX80G9M6S2P2M2M2				Internal	
DX80G2M6W2P2M2M2	External				
DX80G2M6S2P2M2M2	Internal				
DX80G2M6S2P2M2M2	2.4 GHz			External	



Line-Powered Nodes 10 to 30V dc

Model Number	Frequency	I/O		Antenna	Data Sheet
DX80N9X6W4P4	900 MHz	Modbus Enabled	Discrete 4 IN & 4 OUT (sourcing)(sourcing)	Internal	131293
DX80N9X6S4P4				External	
DX80N2X6W4P4	Internal				
DX80N2X6S4P4	External				
DX80N9X6W2P2M2M2	900 MHz	Modbus Enabled	Discrete 2 IN & 2 OUT (sourcing)(sourcing)	Analog 2 IN & 2 OUT (0-20 mA)(0-20 mA)	131295
DX80N9X6S2P2M2M2				Internal	
DX80N2X6W2P2M2M2	External				
DX80N2X6S2P2M2M2	Internal				
DX80N2X6S2P2M2M2	2.4 GHz			External	



FlexPower™ Nodes with Switched Power Outputs FlexPower Supply

Model Number	Frequency	I/O		Notes	Antenna	Data Sheet
DX80N9X2W2N2M2X	900 MHz	Modbus Enabled	Discrete 2 IN & 2 OUT (sinking)(NMOS)	Analog 2 IN (0-20 mA)	Internal	131296
DX80N9X2S2N2M2X				External		
DX80N2X2W2N2M2X	Internal					
DX80N2X2S2N2M2X	External					



FlexPower™ Nodes FlexPower Supply

Model Number	Frequency	I/O		Antenna	Data Sheet	
DX80N9X2W2N2T	900 MHz	Modbus Enabled	Temperature 4 IN (3 Thermocouple* & 1 Thermistor)	Discrete 2 IN & 2 OUT (sinking)(NMOS)	Internal	131297
DX80N9X2S2N2T				External		
DX80N2X2W2N2T	Internal					
DX80N2X2S2N2T	External					
DX80N9X2W0P0R	900 MHz	Modbus Enabled	Temperature 4 IN (3 wire RTD**)		Internal	131597
DX80N9X2S0P0R				External		
DX80N2X2W0P0R	Internal					
DX80N2X2S0P0R	External					
DX80N9X2W2N2M4	900 MHz	Modbus Enabled	Discrete 2 IN & 2 OUT (sinking)(NMOS)	Analog 4 IN (0-20 mA)	Internal	131762
DX80N9X2S2N2M4				External		
DX80N2X2W2N2M4	Internal					
DX80N2X2S2N2M4	External					
DX80N9X2S0P0Z0	900 MHz		M-GAGE™	Internal	131598	
DX80N2X2S0P0Z0	2.4 GHz		(Internal sensor, internal battery, multi-year life)	Internal		



* Thermocouple units default to J-type. Other types configurable
** RTD units default to 3-wire 100 Ohm. Other types configurable

SureCross™ Accessories

Sensors

Optimized for use with FlexPower™ Systems



Model Number	Supply Voltage	Description	Sensing Mode	Range	Output Type	Connection	Data Sheet*
QT50ULBQ6-75390	FlexPower™	U-GAGE® Ultrasonic		200 mm - 8 m	Selectable: 0 to 10V dc or 4 to 20 mA	5-pin Euro QD	70137
SM312LPQD-76885		MINI-BEAM® Photoelectric		3 m	Bipolar NPN/PNP	4-pin Euro QD	69943
SM312DQD-75904				380 mm	Bipolar NPN/PNP	4-pin Euro QD	

* Data sheets are for standard product, contact factory for additional supporting literature.

EZ-LIGHT™ Indicators

Multi-Color, 7-function



Model Number	Construction	Connection	LED Function	Inputs	Data Sheet
M18GRY2PQ	18 mm mount Nickel-plated brass	4-pin Euro QD	Choose Red, Yellow or Green ON, flashing or alternating 	PNP	121902
T30GRY2PQ	30 mm mount Thermoplastic polyester				
K50LGRY2PQ	30 mm mount Thermoplastic polyester				
K80LGRY2PQ	Flat or DIN mount Thermoplastic polyester				

FlexPower™ Supplies



Model Number	Voltage Supplied	Description	Connection	Housing	Data Sheet
DX81	FlexPower Battery Module to supply FlexPower Node	Module driven by one lithium primary battery**	5-pin Euro QD	IP67	131596
DX121		Module driven by six lithium primary batteries**			131628

**Replacement lithium primary battery model number is BWA-BATT-001

AC Power Supply Options



Model Number	Voltage Supplied	Description	Connection	Housing	Data Sheet
SPS101Q	12V dc @ 120 mA max	Converts 105 - 130V ac, 60 Hz to 12V dc (SPST e/m Relay Output)	Sensor Connection: 5-pin Euro QD AC Power Connection: 5-pin Mini QD	IP54	66959
SPS101SQ		Converts 105 - 130V ac, 60 Hz to 12V dc (Optically Isolated SPST Solid-state Output)			
EZAC-E-QE5-QS5	24V dc @ 700 mA	Converts 100 - 230V ac to 24V dc (no output)		IP65	120321
PS24W	24V dc @ 500 mA	Converts 100 - 240V ac to 24V dc North America (wall plug)	5-pin Euro QD	Non-industrial (not sealed)	-

Expandable Remote I/O



Model Number	I/O Functionality	Description	Housing	Data Sheet
DX85-4P4M2M2	2 Analog IN, 2 Analog OUT (0-20 mA); 4 Discrete IN (sourcing), 4 Discrete OUT (sourcing)	Modbus RTU Slave Expansion I/O Modules; used to expand Gateway I/O capacity	IP67	131629
DX85-6P6	6 Discrete IN (sourcing), 6 Discrete OUT (sourcing)			131599



Quick-Disconnect (QD) Cables and Cordsets



4-Pin Euro-Style Cables

Model Number	Style	Length	Used With
MQDC-406	Female Straight/ Unterminated	2 m	<ul style="list-style-type: none"> • MINI-BEAM® • EZ-LIGHT™
MQDC-415		5 m	

5-Pin Euro-Style Cables

MQDC1-506.5	Female Straight/ Unterminated	0.5 m	<ul style="list-style-type: none"> • DX80 • DX85 • DX81 • DX121
MQDC1-506		2 m	
MQDC1-515		5 m	

5-Pin Euro-Style Cordsets

Double Ended

DEE2R-51D	Female Straight/ Male Straight	0.3 m	<ul style="list-style-type: none"> • FlexPower™ Module • Expandable I/O Module
DEE2R-53D		1 m	
DEE2R-515D		2.4 m	

5-Pin Mini-Style Cables

MBCC-506	Female Straight/ Unterminated	2 m	<ul style="list-style-type: none"> • AC Power Supplies
MBCC-512		4 m	
MBCC-530		9 m	

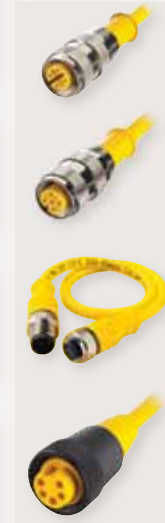

Banner offers the most complete and integrated line of sensing products. No matter what industry you're in—or products you manufacture—Banner has the right sensors to automate your plant, improve overall efficiency, quality and safety. Choose from thousands of standard DC sensing products for line-powered (10 to 30V dc) applications, or low-power sensors—ideal for FlexPower applications. Whatever your need, we have the correct sensor to solve your toughest challenges.

Hardware



Mounting Hardware

Model Number	Description
BWA-HW-001	Replacement mounting hardware packet
BWA-HW-002	Replacement access hardware pack (5 plugs & 4 glands)

Bracket

SMBDX80DIN	DIN-rail flat mounting
------------	------------------------



FlexPower Solar Modules

Create a SureCross network completely independent of line power with solar panels and rechargeable batteries.



SureCross™ Antennas & Cabling Options

- Choose from a variety of direct and remote-mount and high-gain model options to get the best antenna for your application.
- A complete offering of cables and accessories is available for virtually every SureCross module and antenna location challenge.



High-Gain Yagi

Directional Yagi antenna can greatly extend the range of any SureCross device.



Remote Antenna Cables

Offered in various lengths, low-loss cables can be used to mount the antenna outside the SureCross device installation location.



Antenna Adapter Cables

Various cables with many connector types can be used to interface antennas and other accessories to SureCross devices.



Direct-Mount

High-Performance Omni

Provide Omni directional coverage and can be used to increase the transmission range of the entire SureCross network: available in direct- or remote-mount versions.

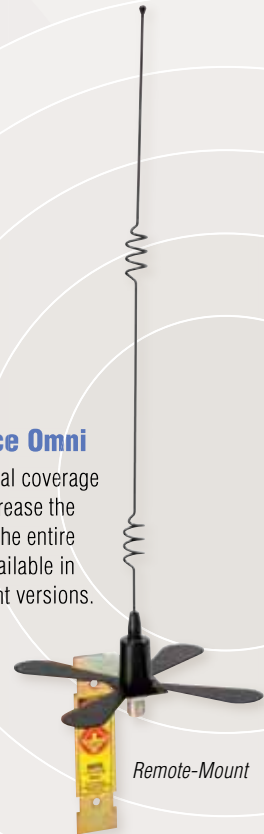

Remote-Mount



Lightning Protectors

Safeguard your SureCross network with simple maintenance free lightning protection devices.



SureCross™ Specifications & Dimensions

Product Specifications and Modifications Disclaimer

All specifications published in this document are subject to change. Banner reserves the right to modify the specifications of products, prior to their order, without notice. Visit bannerengineering.com for up-to-date product information before ordering.

General

Power	+10 - 30V dc or 3.6 - 5.5V dc low power option
Power Consumption	< 1.4 W at 24V dc
Mounting	#10 or M5 (M5 hardware included)
M5 Fasteners – Max. Tightening Torque	0.56 N/m (5 in/lbf)
Case Material	Polycarbonate
Weight	0.26 kg (0.57 lb.)
Indicators	Two LED, bi-color
Switches	Two push buttons
Display	Six character LCD
External Cable Glands	Four PG-7 type, one 1/2-inch NPT type
Cable Glands – Max. Tightening Torque	0.56 N/m (5 in/lbf)

Radio

	900 MHz	2.4 GHz
Range, with Standard 2dB Antenna	Up to 4.8 kilometers (3 miles)*	Up to 3.2 kilometers (2 miles)*
Frequency	902 - 928 MHz ISM band	2.4 - 2.4835 GHz ISM band
Transmit Power	21 dBm conducted	18 dBm conducted, ≤ 20 dBm EIRP
Spread Spectrum Technology	FHSS (Frequency Hopping Spread Spectrum)	FHSS (Frequency Hopping Spread Spectrum)
Antenna Connector	Ext. reverse polarity SMA - 50 Ω	Ext. reverse polarity SMA - 50 Ω
Antenna – Max. Tightening Torque	0.45 N/m (4 in/lbf)	0.45 N/m (4 in/lbf)

* Depending upon the environment and line-of-sight, high gain antennas are available to increase the range.

Environmental

Environmental Rating	NEMA 6 / IEC IP67**
Operating Temperature	-40 to +85° C (electronics); -20 to +80° C (LCD)
Operating Humidity	95% max. relative (non-condensing)
Shock and Vibration	IEC 68-2-6 and IEC 68-2-7 Shock: 30g, 11 milliseconds half sine wave, 18 shocks Vibration: 0.5 mm p-p, 10 - 60 Hz

** Please refer to the SureCross™ DX80 Quick Start Guide, Banner part number 128185, for installation and waterproofing instructions.

Compliance

900 MHz Models	FCC ID TGUDX80 - This device complies with FCC Part 15, Subpart C, 15.247
2.4 GHz Models	FCC ID UE300DX80-2400 - This device complies with FCC Part 15, Subpart C, 15.247 ETSI/EN: In accordance with EN 300 328: V1.7.1 (2006-05)



Dimension Drawings



More information online at bannerengineering.com

Product Information

SureCross™ DXBD Wireless Modules

SureCross DXBD wireless modules are radio outdoor devices with integrated I/O, they operate in extreme environments while maintaining the need for steady wiring runs.

Product Highlights:

- A system includes a Gateway and up to 25 Nodes that operate on the same frequency.
- Each node & accessories are combination of brass and Tin-Plated Steel.
- Input-to-output mapping is controlled by a configured Gateway or supported through serial communication.
- I/O can be tailored to accommodate up to eight functions per device.
- Open design supports input from sensors and devices made by Banner and other manufacturers.
- Prescriptive Plug & Play Software (PWS) and True Ethernet Multiple Access (TEMA) control architecture necessary to ensure reliable data delivery.
- Multiple network and protocol options make it easy to link to industrial host systems.

BANNER ENGINEERING CORP.

Banner offers you the most complete and integrated line of sensing and machine safety products. Whatever industry you're in, or whatever product you manufacture, Banner has the right sensors to automate your plants and improve your overall efficiency, quality and safety.

- Photoelectric Sensors
- Vision Sensors
- Measurement and Inspection Sensors
- Machine Safety Products
- Wireless Products

Add to Favorites...

BANNER ENGINEERING .COM

iSelect™ photoelectrics

World map showing global presence with callouts for various Banner Engineering locations.

Literature & Resources

SureCross™ DXBD Wireless Modules - Literature

Product Name	Part Number	Quantity	Price	Availability
SureCross DXBD Gateway	2000 44 Gateway	1	\$1,200.00	In Stock
SureCross DXBD Node	2000 10, 2000 20, 2000 30, 2000 40, 2000 50, 2000 60, 2000 70, 2000 80, 2000 90, 2000 100, 2000 110, 2000 120, 2000 130, 2000 140, 2000 150, 2000 160, 2000 170, 2000 180, 2000 190, 2000 200	1	\$150.00	In Stock
SureCross DXBD Cable	2000 10, 2000 20, 2000 30, 2000 40, 2000 50, 2000 60, 2000 70, 2000 80, 2000 90, 2000 100, 2000 110, 2000 120, 2000 130, 2000 140, 2000 150, 2000 160, 2000 170, 2000 180, 2000 190, 2000 200	1	\$25.00	In Stock

Applications & Tutorials

iKnow

Wave Characteristics

The following properties define wave and are responsible for how waves behave:

- Wavelength:** the distance between the peaks or troughs of two waves.
- Frequency:** the number of oscillations per second. The constant part of measurement-specific, which is one cycle per second.
- Amplitude:** the strength of a signal. The stronger the signal, the greater the energy it carries.
- Phase:** the relative relationship between two waves.

Car Wash Solutions



1.888.3.SENSOR (1.888.373.6767)

Banner Engineering Corp., 9714 Tenth Avenue North, Minneapolis, MN 55441 U.S.A.
 Phone 763.544.3164 Fax 763.544.3213 bannerengineering.com email: sensors@bannerengineering.com
 PRINTED IN U.S.A. Copyright, 2007 Banner Engineering Corp.

Overview: To use Ethernet communication with the DX80 Gateway Pro, configure the IP address of your computer.

Typical IP Address:
192.168.0.2

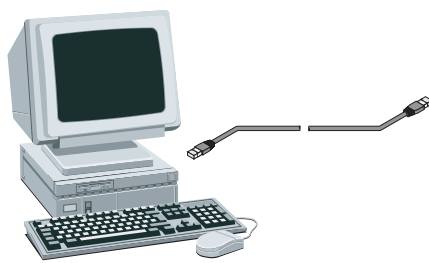

Default IP Address:
192.168.0.1

Procedure: To change the IP address of a Windows 2000 computer, do the following:

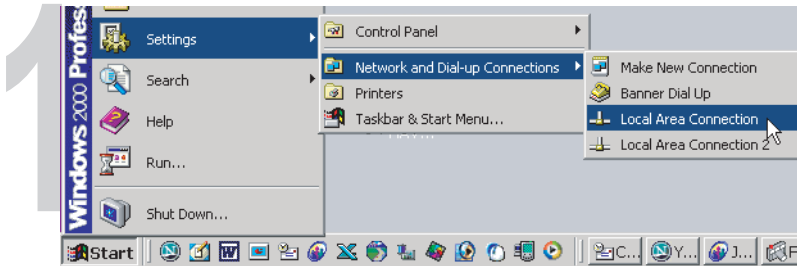

• Click **Start > Network and Dial-up Connections > Local Area Connection**

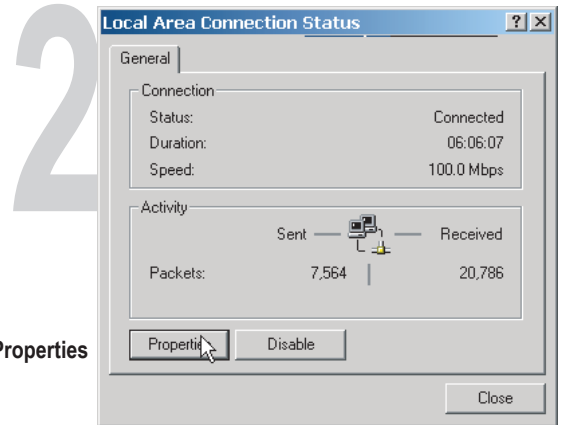

• Click **Properties**

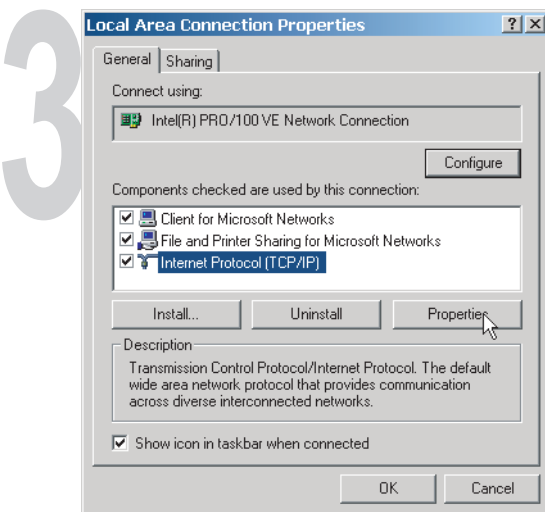

• Choose **Internet Protocols (TCP/IP)** and click **Properties**

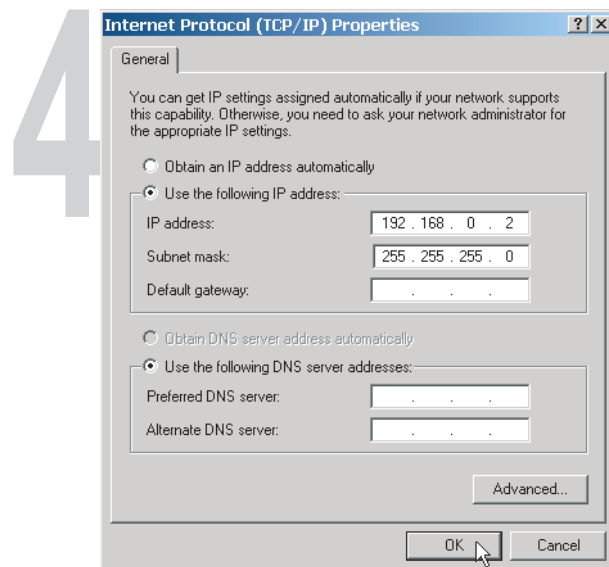

• Write down the existing address of your PC before changing it:

- Choose **Use the following IP Address**
- Change the IP Address to **192.168.0.2**
- Change the Subnet Mask to **255.255.255.0**
- Click **OK**

Overview: To use Ethernet communication with the DX80 Gateway Pro, configure the IP address of your computer.

Typical IP Address:
192.168.0.2

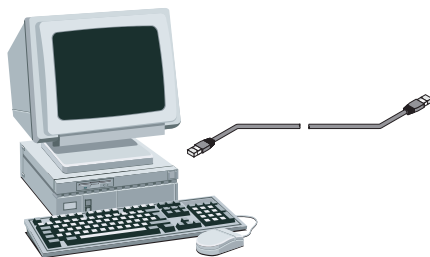

Default IP Address:
192.168.0.1

Procedure: To change the IP address of a Windows XP computer, do the following:

1

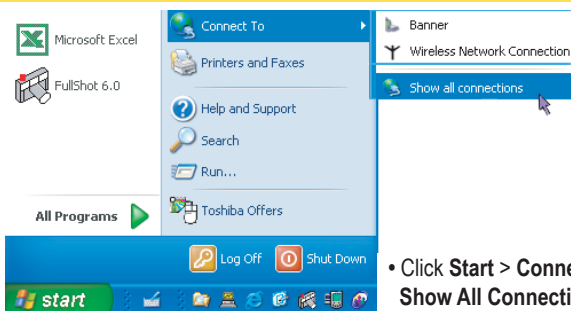

• Click Start > Connect To > Show All Connections

2

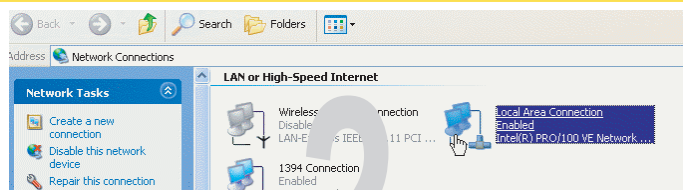

• Choose your Local Area Connection

3

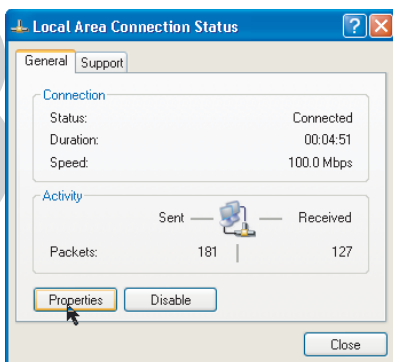

• Click Properties

4

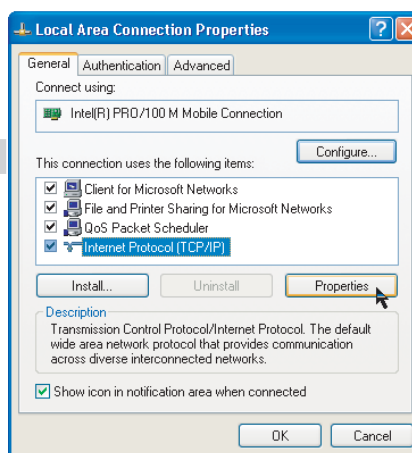

• Choose Internet Protocol (TCP/IP) and click Properties

5

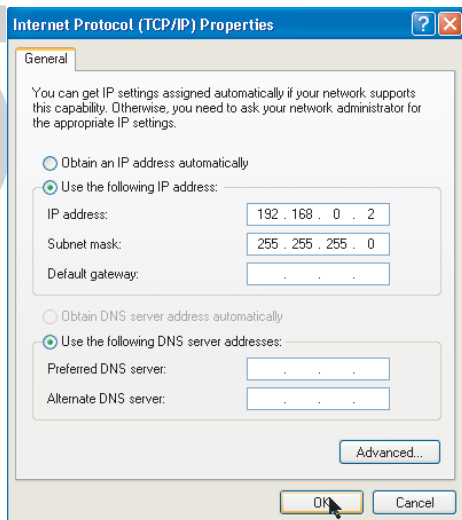

- Write down the existing address of your PC before changing it:
- Choose **Use the following IP Address**
- Change the IP Address to **192.168.0.2**
- Change the Subnet Mask to **255.255.255.0**
- Click **OK**

Overview: To use Ethernet communication with the DX80 Gateway Pro, configure the IP address of your computer.

Typical IP Address:
192.168.0.2

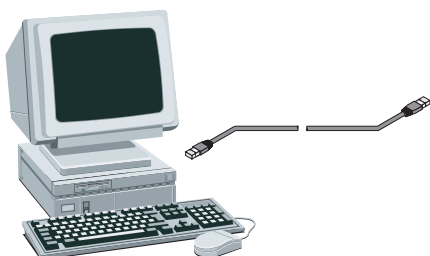

Default IP Address:
192.168.0.1

Procedure: To change the IP address of a Windows NT computer, do the following:

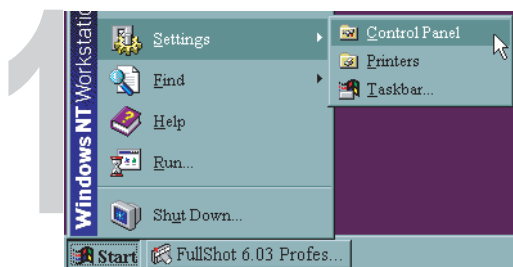

• Click **Start > Settings > Control Panel**

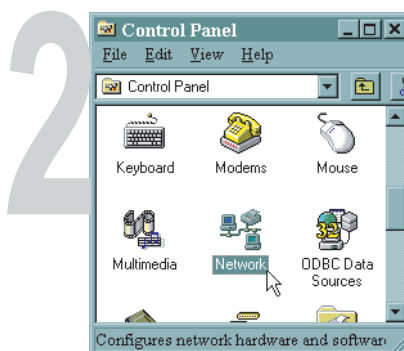

• Double-click the **Network** icon

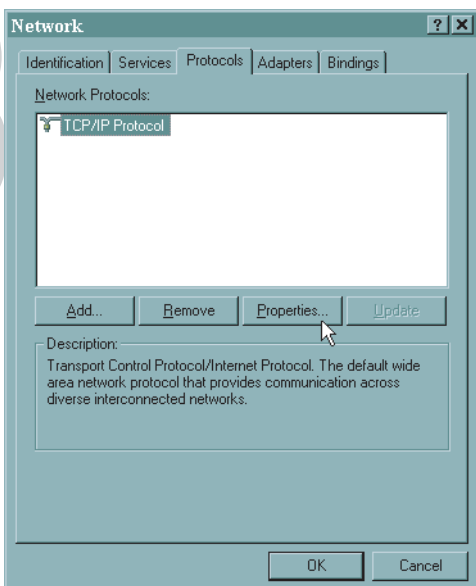

• Click the **Protocols** tab > **TCP/IP Protocol** > **Properties**

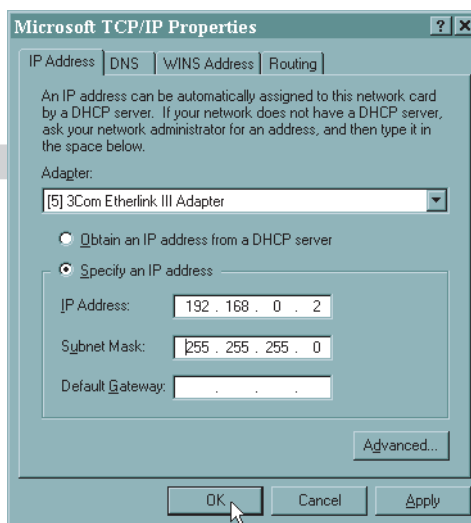

• Write down the existing address of your PC before changing it:

- Choose **Specify an IP Address**
- Change the IP Address to **192.168.0.2**
- Change the Subnet Mask to **255.255.255.0**
- Click **OK**

Overview: To use Ethernet communication with the DX80 Gateway Pro, configure the IP address of your computer.

Typical IP Address:
192.168.0.2

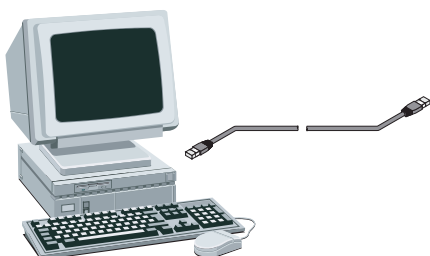

Default IP Address:
192.168.0.1



Procedure: To change the IP address of a Windows 95, 98, or ME computer, do the following:

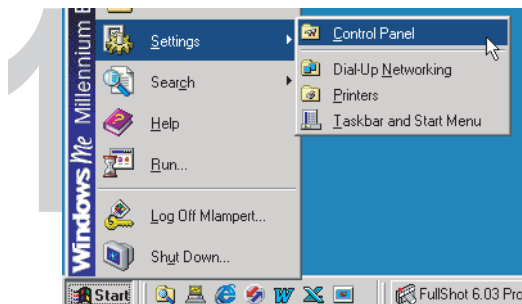

• Click **Start > Settings > Control Panel**

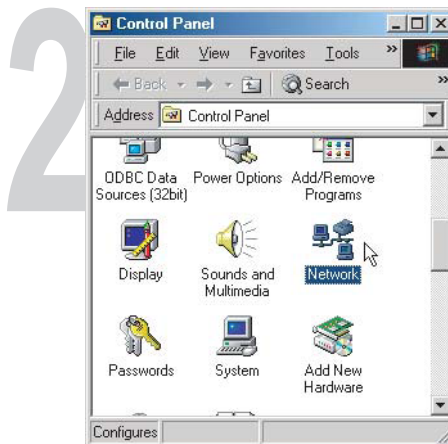

• Double-click the **Network** icon

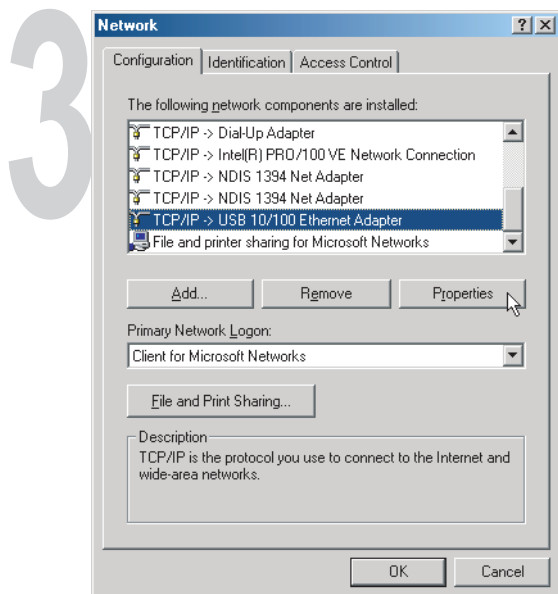

- Scroll down the components list
- Click on your Network Card after TCP/IP
- Click on **Properties**

NOTE: There may be more than one TCP/IP component on the list, so choose one that is similar to the description of your Network Card.

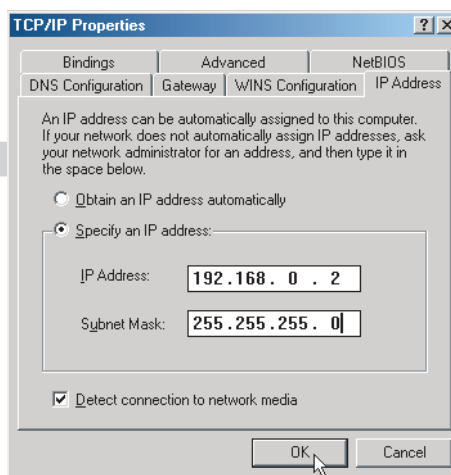

- Click the **IP Address** tab
- Write down the existing address of your PC before changing it:
- Choose **Specify an IP Address**
- Change the IP Address to **192.168.0.2**
- Change the Subnet Mask to **255.255.255.0**
- Click **OK**
- Reboot the PC